

Please write clearly in block capitals.

Centre number

Candidate number

Surname \_\_\_\_\_

Forename(s) \_\_\_\_\_

Candidate signature \_\_\_\_\_

I declare this is my own work.

# A-level PHYSICS

## Paper 2

Thursday 6 June 2024

Morning

Time allowed: 2 hours

### Materials

For this paper you must have:

- a pencil and a ruler
- a scientific calculator
- a Data and Formulae Booklet
- a protractor.

### Instructions

- Use black ink or black ball-point pen.
- Fill in the boxes at the top of this page.
- Answer **all** questions.
- You must answer the questions in the spaces provided. Do not write outside the box around each page or on blank pages.
- If you need extra space for your answer(s), use the lined pages at the end of this book. Write the question number against your answer(s).
- Do all rough work in this book. Cross through any work you do not want to be marked.
- Show all your working.

### Information

- The marks for questions are shown in brackets.
- The maximum mark for this paper is 85.
- You are expected to use a scientific calculator where appropriate.
- A Data and Formulae Booklet is provided as a loose insert.

For Examiner's Use	
Question	Mark
1	
2	
3	
4	
5	
6	
7	
8–32	
<b>TOTAL</b>	



**Section A**Answer **all** questions in this section.**0 1**

A room contains dry air at a temperature of 20.0 °C and a pressure of 105 kPa.

**0 1 . 1**

Show that the amount of air in each cubic metre is about 40 mol.

**[1 mark]****0 1 . 2**The density of the dry air is 1.25 kg m<sup>-3</sup>.Calculate  $c_{\text{rms}}$  for the air molecules.

Give your answer to an appropriate number of significant figures.

**[3 marks]**

$$c_{\text{rms}} = \underline{\hspace{10em}} \text{ m s}^{-1}$$

**0 1 . 3**Calculate, in K, the change of temperature that will double  $c_{\text{rms}}$  for the air molecules.**[2 marks]**

$$\text{change of temperature} = \underline{\hspace{10em}} \text{ K}$$



0 1 . 4

A room contains moist air at a temperature of  $20\text{ }^{\circ}\text{C}$ .  
 A dehumidifier cools and then condenses water vapour from the moist air.  
 The final temperature of the liquid water that collects in the dehumidifier is  $10\text{ }^{\circ}\text{C}$ .  
 Drier air leaves the dehumidifier at a temperature of  $20\text{ }^{\circ}\text{C}$ .

**Table 1** compares the air flowing into and out from the dehumidifier.

**Table 1**

	$\frac{\text{mass of water}}{\text{mass of air}}$
moist air flowing in	0.0057
drier air flowing out	0.0037

In one hour, a volume of  $960\text{ m}^3$  of air flows through the dehumidifier.  
 Assume that the density of the air remains constant at  $1.25\text{ kg m}^{-3}$ .

Determine how much heat energy is removed in one hour from the water vapour by the dehumidifier.

specific heat capacity of water vapour =  $1860\text{ J kg}^{-1}\text{ K}^{-1}$

specific latent heat of vaporisation of water =  $2.3 \times 10^6\text{ J kg}^{-1}$

**[3 marks]**

heat energy removed = \_\_\_\_\_ J

9

Turn over ►



0 2

**Figure 1** shows a circuit used to charge capacitor **C**.  
The battery has negligible internal resistance.

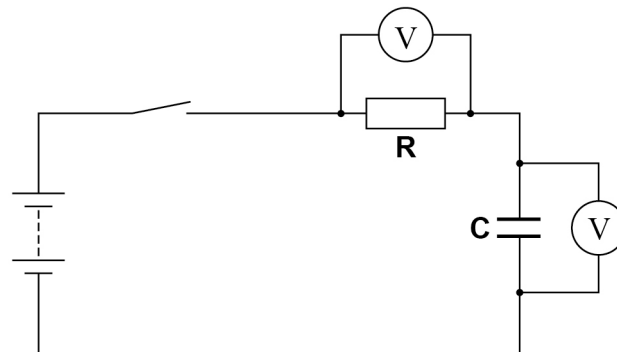
**Figure 1**

The capacitance of **C** is known.

0 2 . 1

The switch is closed at time  $t = 0$  and the potential difference  $V_C$  across **C** is recorded at different times  $t$ .

**Figure 2** shows the variation of  $V_C$  with  $t$ .

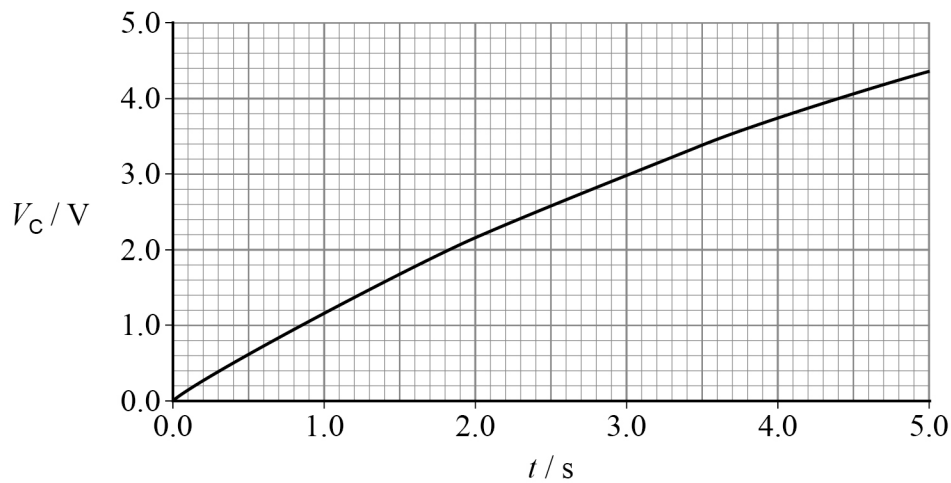
**Figure 2**

Explain how a gradient of the graph in **Figure 2** can be used to determine the initial current  $I_0$  in the circuit.

**[2 marks]**

---



---



---



---



---



0 2 . 2

The potential difference  $V_R$  across **R** is also recorded.

**Figure 3** shows the variation of  $V_R$  with  $t$  between  $t = 20$  s and  $t = 45$  s.

**Figure 3**

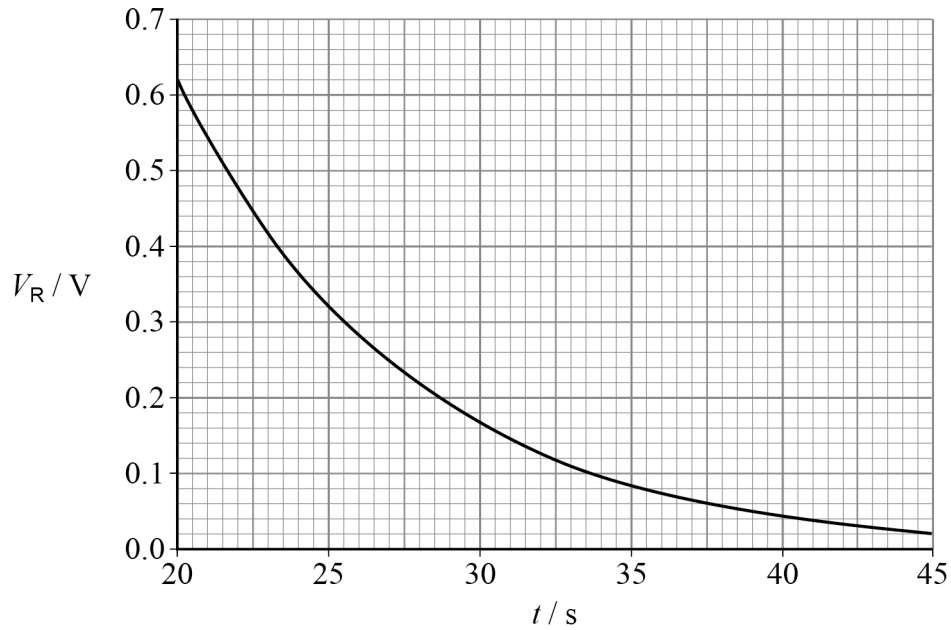

The capacitance of **C** is  $31.0 \mu\text{F}$ .

Determine, using **Figure 3**, the time constant of the circuit.  
Go on to show that the resistance of **R** is about  $2.4 \times 10^5 \Omega$ .

[2 marks]

time constant = \_\_\_\_\_ s

resistance = \_\_\_\_\_  $\Omega$

**Question 2 continues on the next page**

Turn over ►



**0 2 . 3** The current  $I_0$  at time  $t = 0$  is  $3.6 \times 10^{-5}$  A.

Determine the time at which  $V_C$  is 6.0 V.

**[3 marks]**

time = \_\_\_\_\_ s

**0 2 . 4** **Figure 4** shows two fully charged parallel-plate capacitors  $C_1$  and  $C_2$  in a circuit. A dielectric fills the space between the plates of  $C_1$  and air fills the space between the plates of  $C_2$ .

**Figure 4**

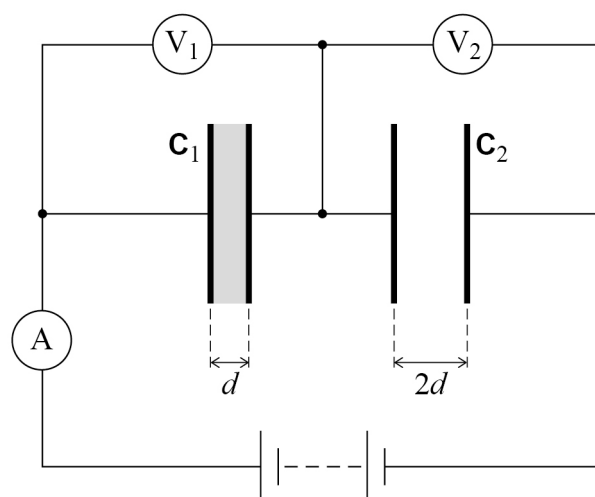

Table 2 gives information about  $C_1$  and  $C_2$ .

Table 2

	$C_1$	$C_2$
charge	$Q$	$Q$
surface area	$S$	$S$
potential difference	$V_1$	$V_2$
plate separation	$d$	$2d$
dielectric constant	4.0	1.0

Determine  $\frac{V_1}{V_2}$ .

[2 marks]

$$\frac{V_1}{V_2} =$$

9

Turn over for the next question

Turn over ►



0 3

A conducting rod is held horizontally in an east–west direction. The magnetic flux density of the Earth’s magnetic field is  $4.9 \times 10^{-5} \text{ T}$  and is directed at an angle of  $68^\circ$  to the ground.

0 3

. 1

**Figure 5** shows the arrangement. The rod has a length of 2.0 m.

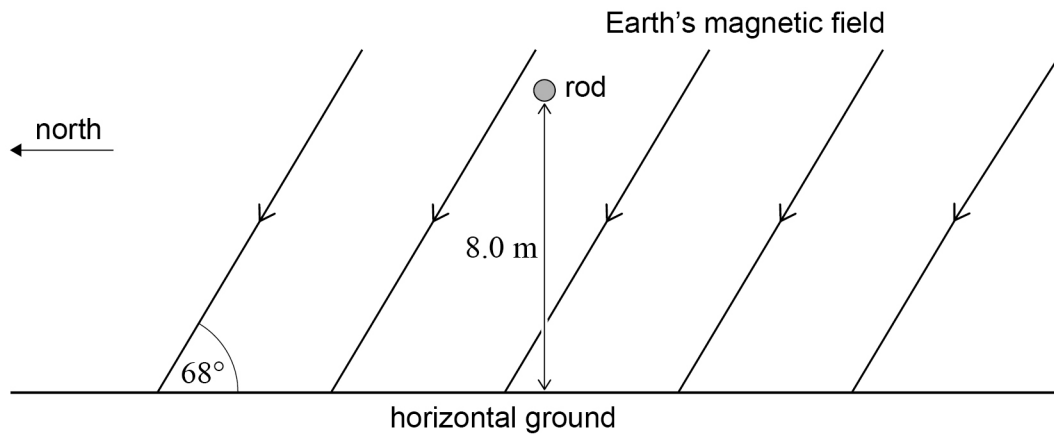
**Figure 5**

The rod is released and falls 8.0 m to the ground. It remains in a horizontal east–west direction as it falls.

Determine the average emf across the rod during its fall to the ground. Assume that air resistance is negligible.

**[3 marks]**

average emf = \_\_\_\_\_ V



0 3 . 2

The rod is returned to its original position. It is now supported by a non-conducting pole that is hinged on the ground as shown in **Figure 6**. The pole is initially vertical and is then released. The rod and pole can fall to the ground to the left or to the right.

**Figure 6**

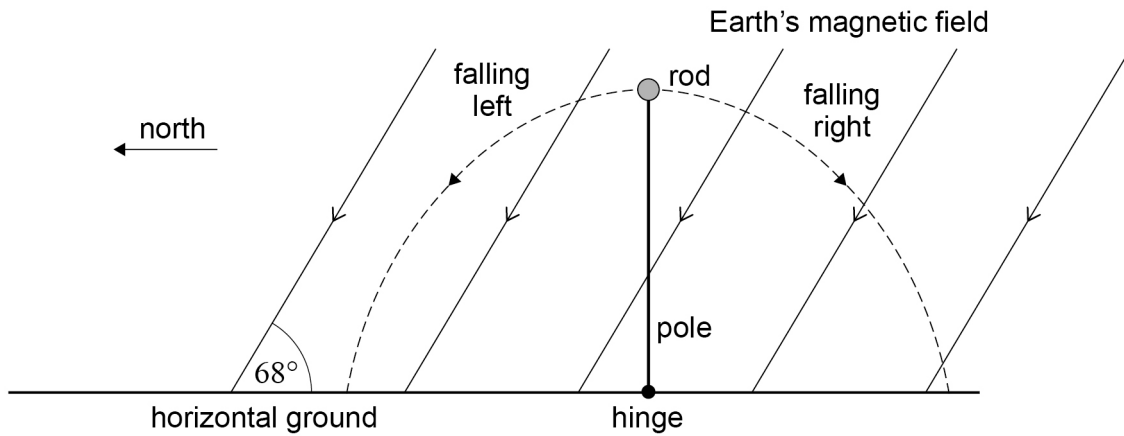

During each fall there are changes in the magnitude and direction of the induced emf. These changes differ depending on whether the rod falls to the left or to the right.

Explain any changes in the magnitude and direction of the induced emf as the rod falls:

- to the left
- to the right.

**[4 marks]**

left \_\_\_\_\_

\_\_\_\_\_

\_\_\_\_\_

\_\_\_\_\_

right \_\_\_\_\_

\_\_\_\_\_

\_\_\_\_\_

\_\_\_\_\_

7

Turn over ►



**0 4 . 1** One purpose of the coolant in a thermal nuclear reactor is to maintain a safe working temperature within the core.

State the other purpose.

**[1 mark]**

---

---

---

**0 4 . 2** State **two** properties that engineers consider when choosing a liquid to use as a coolant in a thermal nuclear reactor.

**[2 marks]**

1 \_\_\_\_\_

---

2 \_\_\_\_\_

---

**0 4 . 3** Explain how the power output of a thermal nuclear reactor is decreased.

**[2 marks]**

---

---

---

---

---

---

---

**5**



**Turn over for the next question**

*Do not write  
outside the  
box*

**DO NOT WRITE ON THIS PAGE  
ANSWER IN THE SPACES PROVIDED**

**Turn over ►**



0 5

A satellite  $S_1$  is placed in a circular orbit around the Earth so that observations of the far side of the Moon can be made continuously.

$S_1$  has the same angular speed as the Moon so that the centres of the Earth, the Moon and  $S_1$  are always in a straight line.

**Figure 7** shows two positions of the Moon and  $S_1$  as they orbit the Earth.

**Figure 7**

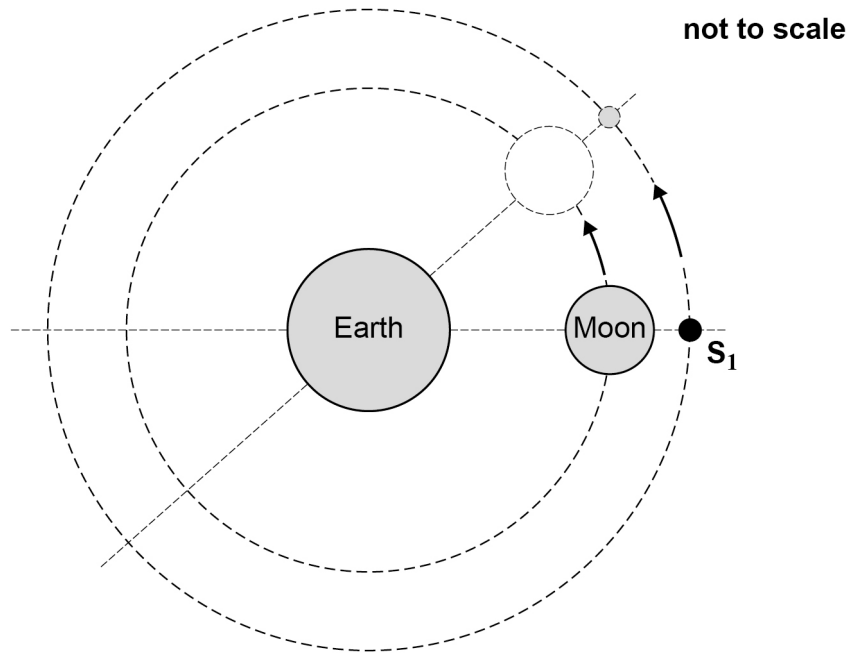

0 5 . 1

The resultant force on  $S_1$  is due to the gravitational forces from the Earth and the Moon.

The magnitude of the Earth's gravitational field strength at the orbital radius of  $S_1$  is  $1.98 \times 10^{-3} \text{ N kg}^{-1}$ .

The magnitude of the Moon's gravitational field strength at the orbital radius of  $S_1$  is  $g_M$ .

Show that  $g_M$  is approximately  $1.2 \times 10^{-3} \text{ N kg}^{-1}$ .

period of the Moon's orbit = 27.3 days

orbital radius of  $S_1 = 4.489 \times 10^5 \text{ km}$

[3 marks]

0 5 . 2

Calculate the distance from  $S_1$  to the centre of the Moon.

mass of the Moon =  $7.35 \times 10^{22} \text{ kg}$

[2 marks]

distance = \_\_\_\_\_ m

Question 5 continues on the next page

Turn over ►



0 5 . 3

Another satellite  $S_2$  is placed in a circular orbit between the Earth and the Moon.  $S_2$  always views the near side of the Moon.  $S_2$  also has the same angular speed as the Moon so that the centres of the Earth, the Moon and  $S_2$  are always in a straight line. **Figure 8** shows two positions of the Moon and  $S_2$  as they orbit the Earth.

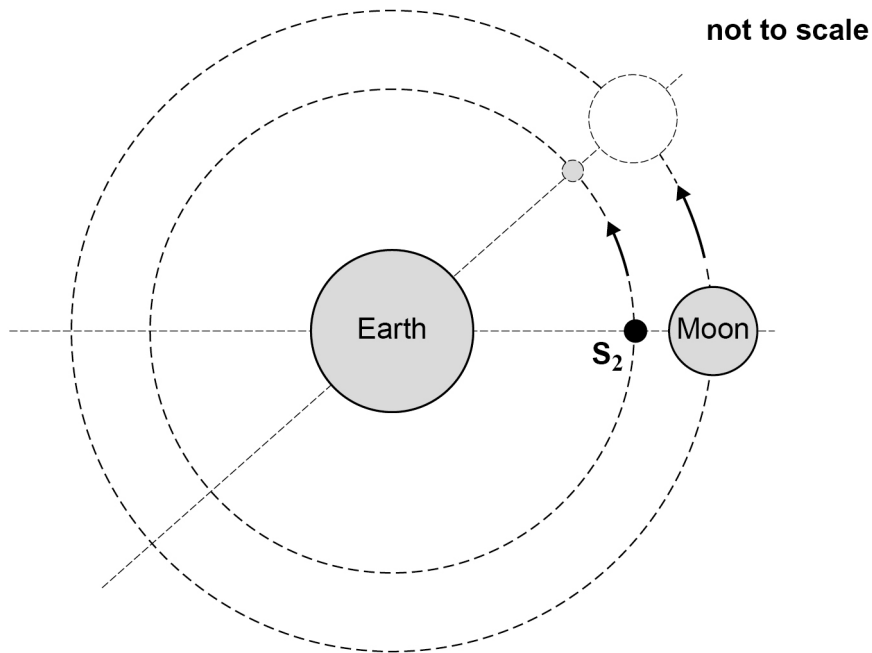
**Figure 8**

Explain how the resultant force on  $S_2$  due to the gravitational fields of the Earth and the Moon causes  $S_2$  to orbit with the same angular speed as the Moon. No calculations are required.

**[3 marks]**

---



---



---



---



---



---



---



---



---



---



**0 6 . 1** The electric potential at a point in an electric field is  $-4.0\text{ V}$ .

Explain what is meant by this statement.

**[3 marks]**

---

---

---

---

---

---

---

**Question 6 continues on the next page**

**Turn over ►**



**Figure 9** shows an arrangement for confining groups of electrons to small regions inside a block of gallium arsenide.

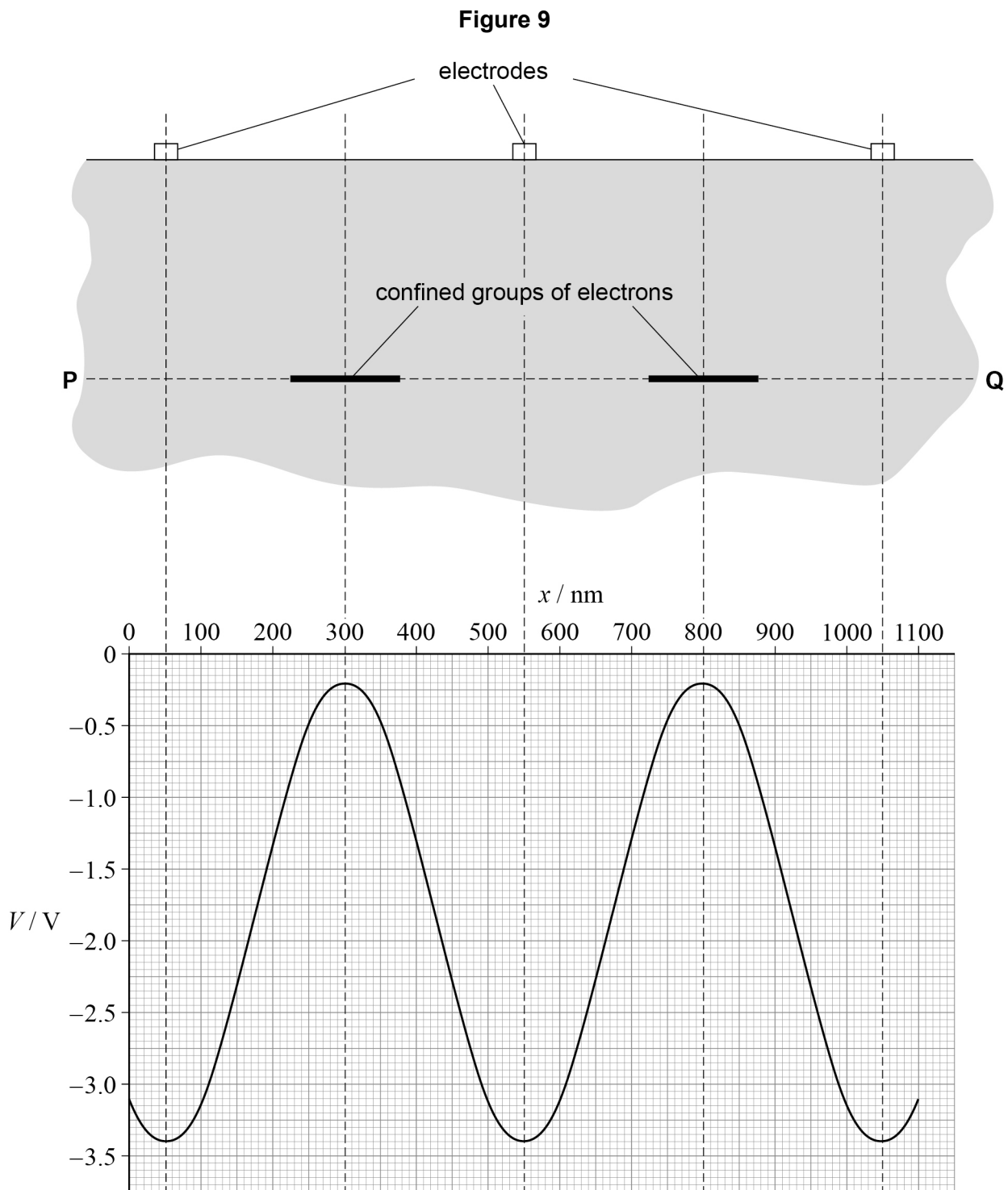

Electrons can only move along the line **PQ** in the block.

When a suitable electric potential is applied to the electrodes, the electrons are confined to the regions shown in **Figure 9**.

The graph in **Figure 9** shows how the electric potential  $V$  varies with distance  $x$  along **PQ**.



0 6 . 2

Determine, using the graph in **Figure 9**, the maximum magnitude of the electric field. State an appropriate unit for your answer.

**[4 marks]**

maximum magnitude = \_\_\_\_\_ unit \_\_\_\_\_

0 6 . 3

An electron at rest at  $x = 300 \text{ nm}$  gains kinetic energy and moves to  $x = 800 \text{ nm}$ .

Determine the minimum kinetic energy required by the electron.

**[2 marks]**

minimum kinetic energy = \_\_\_\_\_ J

**Question 6 continues on the next page****Turn over ►**



07

A team of students uses 900 dice, each with  $n$  sides, to model the decay of a radioactive material. Each dice represents a single undecayed nucleus. A throw of the dice represents a constant time interval.

When the dice are thrown, those that show a 1 represent decayed nuclei and are removed.

The students count the number  $N$  of 'undecayed' dice that remain.

The procedure is repeated using the undecayed dice.

**Figure 10** shows the students' data.

**Figure 10**

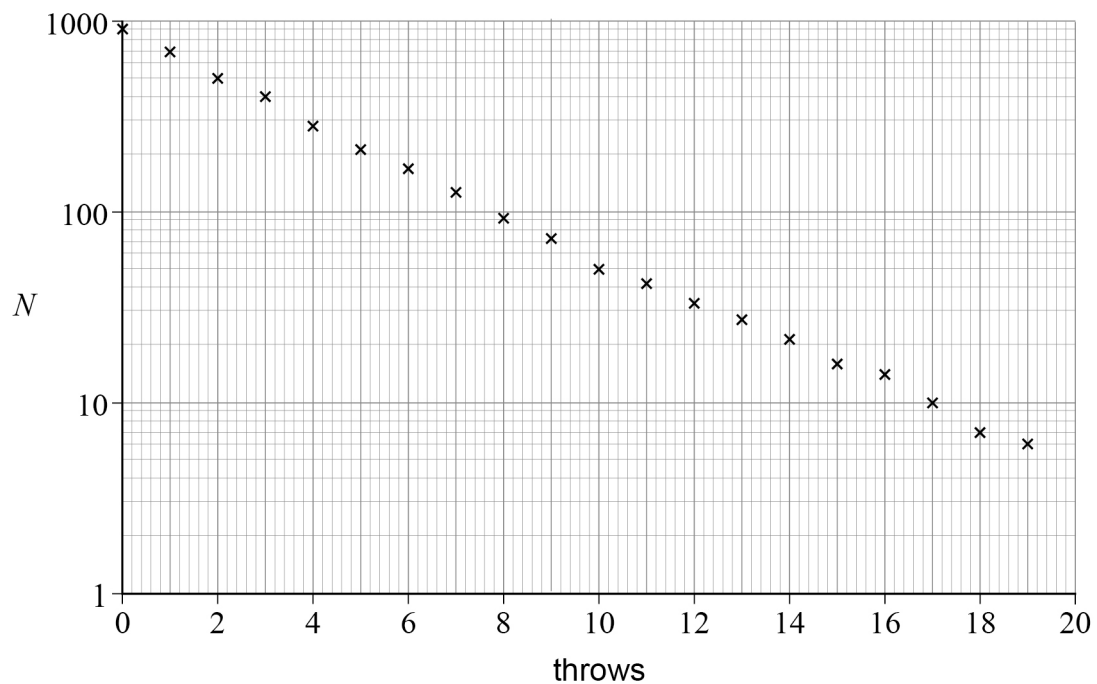

07

1

Explain why  $N$  has been plotted on a logarithmic scale in **Figure 10**.

[1 mark]

---



---



---

Question 7 continues on the next page

Turn over ►



07.2

In this experiment, a decay constant  $\lambda$  can be defined that models the radioactive decay constant.

Determine  $\lambda$ .

Go on to use your value for  $\lambda$  to show that  $n = 4$  for the dice used in this experiment.

[5 marks]

$\lambda =$  \_\_\_\_\_  $\text{throw}^{-1}$

07.3

A typical radioactive source used in schools has an activity of 100 kBq.  
A radioactive source used in a hospital has an activity of 370 GBq.

State **one** safety measure when using a radioactive source in a school laboratory.

Go on to discuss how this safety measure needs to be adapted for safe use of the hospital radioactive source.

[2 marks]

---

---

---

---

---

---

---



**0 7 . 4** X-rays are a form of ionising radiation.

A person has check-ups with a dentist every six months.  
The dentist only takes X-ray images when the person has reported a problem.

Suggest why.

**[2 marks]**

---

---

---

---

---

---

---

---

**10**

**END OF SECTION A**

**Turn over ►**



**Section B**

Each of Questions **08** to **32** is followed by four responses, **A**, **B**, **C** and **D**.

For each question select the best response.

Only **one** answer per question is allowed.

For each question, completely fill in the circle alongside the appropriate answer.

CORRECT METHOD 

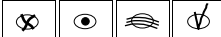
WRONG METHODS 

If you want to change your answer you must cross out your original answer as shown. 

If you wish to return to an answer previously crossed out, ring the answer you now wish to select as shown. 

You may do your working in the blank space around each question but this will not be marked.  
Do **not** use additional sheets for this working.

**0 8** In which process is work done by an ideal gas?

[1 mark]

- A** doubling the pressure at constant volume
- B** doubling the volume at constant pressure
- C** doubling the absolute temperature at constant volume
- D** doubling the pressure at constant temperature



**0 9**

Three molecules have speeds  $2.00v$ ,  $4.00v$  and  $5.00v$ .

What is the  $c_{\text{rms}}$  speed of these molecules?

**[1 mark]**

**A**  $3.50v$

**B**  $3.67v$

**C**  $3.87v$

**D**  $26.0v$

**1 0**

An ideal gas is enclosed in an insulated container with a small electric heater.

The initial temperature of the gas is  $300\text{ K}$ .

The product of pressure and volume is  $5000\text{ J}$ .

The gas expands at constant pressure and does  $1660\text{ J}$  of work.

What is the final temperature of the gas?

**[1 mark]**

**A**  $300\text{ K}$

**B**  $400\text{ K}$

**C**  $450\text{ K}$

**D**  $900\text{ K}$

**1 1**

An air-filled parallel-plate capacitor and a resistor are connected in series across the terminals of a battery.

The plates of the capacitor are then moved further apart.

This change results in

**[1 mark]**

**A** a decrease in the potential difference across the capacitor plates.

**B** a decrease in the charge held on the capacitor plates.

**C** an increase in the energy stored on the capacitor.

**D** an increase in the capacitance of the capacitor.

**Turn over ►**

**1 2**

Which change will increase the efficiency of a transformer?

**[1 mark]**

- A** increasing the thickness of the iron layers in the laminated core
- B** decreasing the frequency of the ac input voltage
- C** decreasing the diameter of the copper wire in the primary coil
- D** increasing the distance between the primary coil and the secondary coil

**1 3**

A signal generator supplies a sinusoidal root mean square voltage of 7.0 V. The sinusoidal voltage is displayed on an oscilloscope screen. The screen has eight vertical divisions.

Which volts/division setting will display the tallest complete waveform?

**[1 mark]**

- A** 1.5 V div<sup>-1</sup>
- B** 2.0 V div<sup>-1</sup>
- C** 2.5 V div<sup>-1</sup>
- D** 3.0 V div<sup>-1</sup>



**1 4**

Two signals that have the same frequency are displayed simultaneously on an oscilloscope.

The display is shown with the time-base set to  $5 \text{ ms div}^{-1}$ .

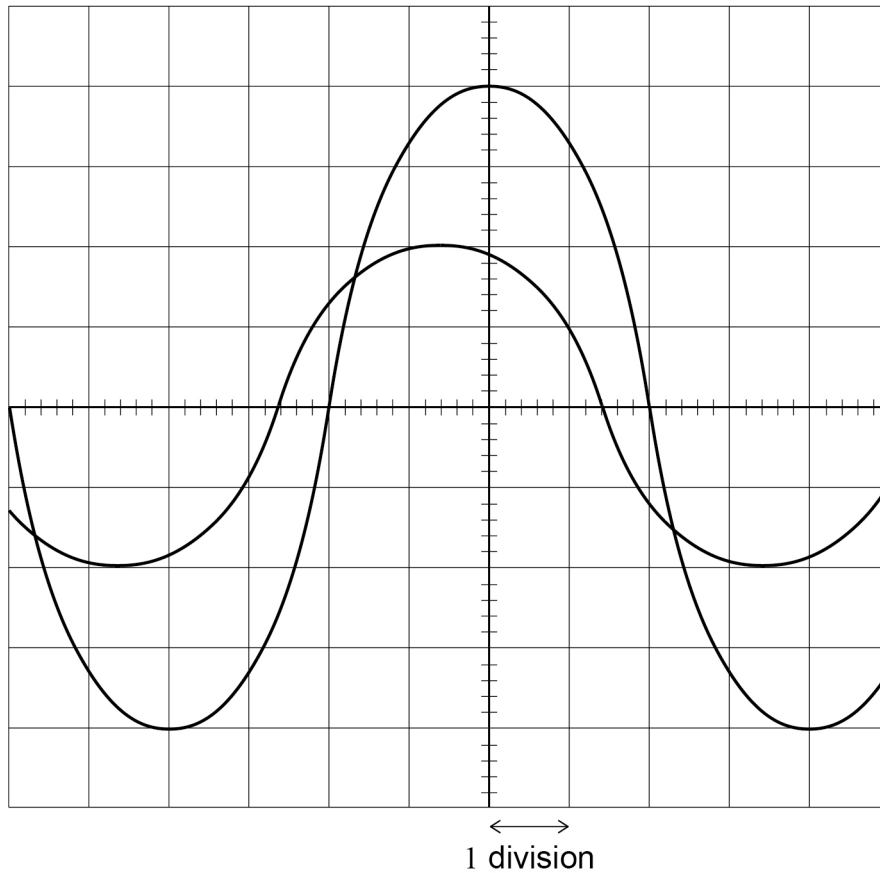

Which row shows the frequency of both signals and the phase difference between them?

**[1 mark]**

	Frequency of both signals / Hz	Phase difference / rad	
<b>A</b>	50	$0.30\pi$	<input type="checkbox"/>
<b>B</b>	50	$0.15\pi$	<input type="checkbox"/>
<b>C</b>	25	$0.30\pi$	<input type="checkbox"/>
<b>D</b>	25	$0.15\pi$	<input type="checkbox"/>

Turn over ►



**1 5**

A transmission cable consists of many strands of wire. Electrical energy is transmitted along the cable at a frequency of 50 Hz.

Which change gives the largest increase in the efficiency of the electrical energy transfer along the cable?

**[1 mark]**

- A** doubling the transmission voltage of the cable
- B** doubling the current in the cable
- C** halving the resistivity of the material of the wires
- D** halving the number of wires in the cable

**1 6**

An electron enters a uniform magnetic field at right angles to the field.

The flux density of the field is  $B$ .

The electron moves with a non-relativistic speed  $v$  in a circular path of radius  $r$ .

What is the number of circuits completed by the electron in one second?

**[1 mark]**

- A**  $\frac{2\pi m_e}{Be}$
- B**  $\frac{2\pi r}{v}$
- C**  $\frac{v}{\pi r}$
- D**  $\frac{Be}{2\pi m_e}$



**1 7** The following reaction occurs when a proton and a carbon-13 ( $^{13}_6\text{C}$ ) nucleus fuse.

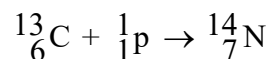

mass of  $^{13}_6\text{C}$  nucleus = 13.00007 u

mass of  $^{14}_7\text{N}$  nucleus = 13.99925 u

mass of proton = 1.00728 u

What is the quantity of energy released?

[1 mark]

- A** 0.5 MeV
- B** 1.1 MeV
- C** 7.5 MeV
- D** 8.8 MeV

**1 8** The equation represents a typical fission reaction.

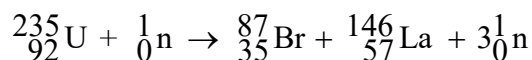

Which statement about this reaction is **not** true?

[1 mark]

- A**  $^{146}_{57}\text{La}$  has the greatest binding energy per nucleon of the three nuclides.
- B** The mass of  $^{235}_{92}\text{U}$  is greater than the sum of the masses of  $^{87}_{35}\text{Br}$  and  $^{146}_{57}\text{La}$ .
- C** The binding energy of the neutrons released in the reaction is zero.
- D** The binding energy of  $^{235}_{92}\text{U}$  is greater than the binding energy of  $^{146}_{57}\text{La}$ .

Turn over ►



**1 9**

5.6 kW h of heat energy is released when 1.0 kg of wood pellets are burnt in a power station.

What is the mass lost in burning 1.0 kg of wood pellets?

**[1 mark]**

**A** 0

**B**  $3.7 \times 10^{-12}$  kg

**C**  $2.2 \times 10^{-10}$  kg

**D**  $6.7 \times 10^{-2}$  kg

**2 0**

The nuclear radius of an element with nucleon number  $x$  is  $r$ .

What is the nuclear radius of an element with nucleon number  $y$ ?

**[1 mark]**

**A**  $r \left( \frac{x}{y} \right)^3$

**B**  $r \left( \frac{y}{x} \right)^3$

**C**  $r \left( \frac{x}{y} \right)^{\frac{1}{3}}$

**D**  $r \left( \frac{y}{x} \right)^{\frac{1}{3}}$



**2 1**

A synchronous orbit of the Earth has a radius  $R$ .

A planet has a mass twice the mass of the Earth. A day on the planet is one quarter of an Earth day.

What is the radius of a synchronous orbit for this planet?

**[1 mark]**

**A**  $\frac{R}{\sqrt[3]{2}}$

**B**  $\frac{R}{\sqrt[3]{16}}$

**C**  $\frac{R}{2}$

**D**  $\frac{\sqrt{2}R}{8}$

**2 2**

An asteroid has a mass of  $2 \times 10^{17}$  kg and an escape velocity of  $40 \text{ m s}^{-1}$ .

What is the order of magnitude of the radius of the asteroid?

**[1 mark]**

**A**  $10^3 \text{ m}$

**B**  $10^4 \text{ m}$

**C**  $10^5 \text{ m}$

**D**  $10^6 \text{ m}$

**Turn over for the next question**

**Turn over ►**



2 3

The diagram shows the gravitational field for a binary star system consisting of two stars **X** and **Y** of equal mass.

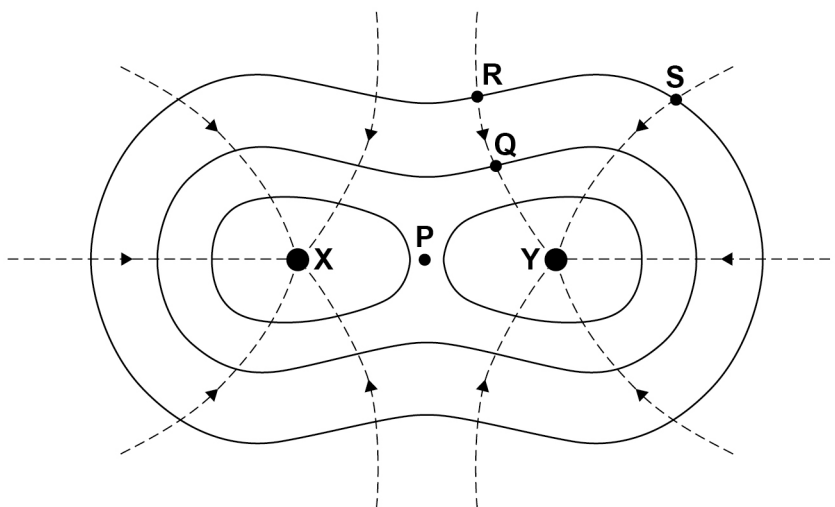

Equipotential lines are shown as solid lines.  
Gravitational field lines are shown as dashed lines.

Which statement is correct?

[1 mark]

- A** More work is done moving from **Q** to **S** to **R** than moving directly from **Q** to **R**.
- B** No work is done moving from **Q** to **R**.
- C** The gravitational field strength is the same at **R** and **S**.
- D** The work done moving from **Q** to **R** and moving from **Q** to **S** is the same.

2 4

Which is equal to  $\epsilon_0$ ?

[1 mark]

- A** the relative permittivity of a vacuum
- B** the charge stored on a capacitor consisting of two parallel plates of area  $1 \text{ m}^2$  separated by  $1 \text{ m}$  when the potential difference between the plates is  $1 \text{ V}$
- C** the work done when moving a  $2 \text{ C}$  charge from infinity to a distance of  $\pi \text{ m}$  from the centre of a metal sphere that carries  $2 \text{ C}$  of charge
- D** the charge on a metal sphere which experiences a force of  $1 \text{ N}$  when its centre is placed  $1 \text{ m}$  from the centre of a metal sphere that carries  $1 \text{ C}$  of charge



**2 5**

The force between two point charges is  $F$ .  
The magnitude of each charge is doubled and the distance between them is halved.

What is the new force between the two charges?

**[1 mark]**

**A**  $16F$

**B**  $8F$

**C**  $2F$

**D**  $F$

**Turn over for the next question**

**Turn over ►**

2 6

Which diagram shows a distribution of charge where the electric potential at **P** and the electric field at **P** are both zero?

[1 mark]

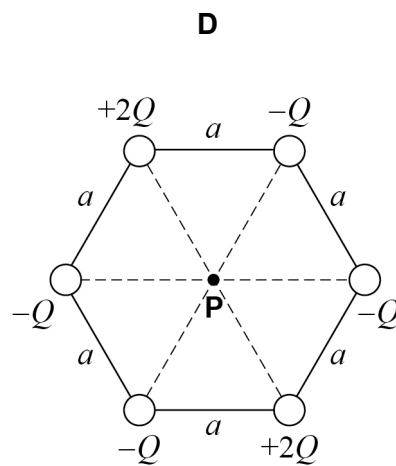
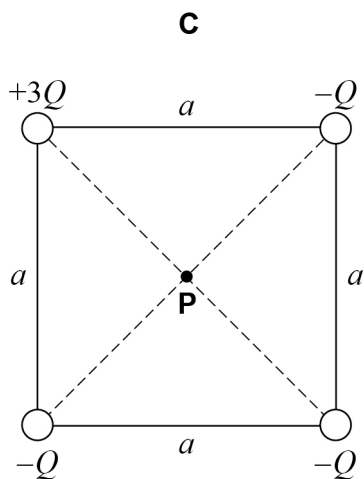
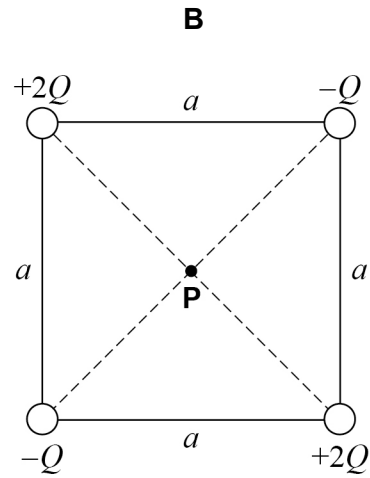
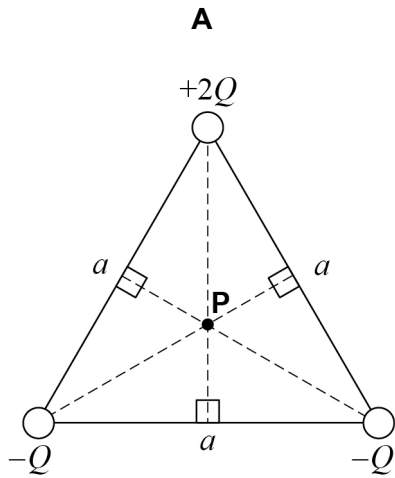
A B C D 

2 7

An ion has a specific charge of  $-7.1 \times 10^7 \text{ C kg}^{-1}$ .  
It is held stationary in a vertical electric field on the surface of the Earth.

What are the magnitude and direction of the electric field?

[1 mark]

- A  $1.38 \times 10^{-7} \text{ V m}^{-1}$  upwards
- B  $1.38 \times 10^{-7} \text{ V m}^{-1}$  downwards
- C  $7.24 \times 10^6 \text{ V m}^{-1}$  upwards
- D  $7.24 \times 10^6 \text{ V m}^{-1}$  downwards

2 8

Which particle pair has the largest magnitude of  $\frac{\text{electrostatic force}}{\text{gravitational force}}$  when separated by the same distance?

[1 mark]

- A an electron and a positive pion
- B a helium nucleus and a proton
- C a proton and a positive pion
- D a proton and an electron

2 9

What can be deduced about the radius  $r$  of a nucleus of gold from the scattering of alpha particles by gold nuclei?

[1 mark]

- A  $r < 10^{-14} \text{ m}$
- B  $r < 10^{-15} \text{ m}$
- C  $r \approx 10^{-15} \text{ m}$
- D  $r \approx 10^{-16} \text{ m}$

Turn over ►



3 0

The graph shows a plot of neutron number  $N$  against proton number  $Z$  for the known atomic nuclei.

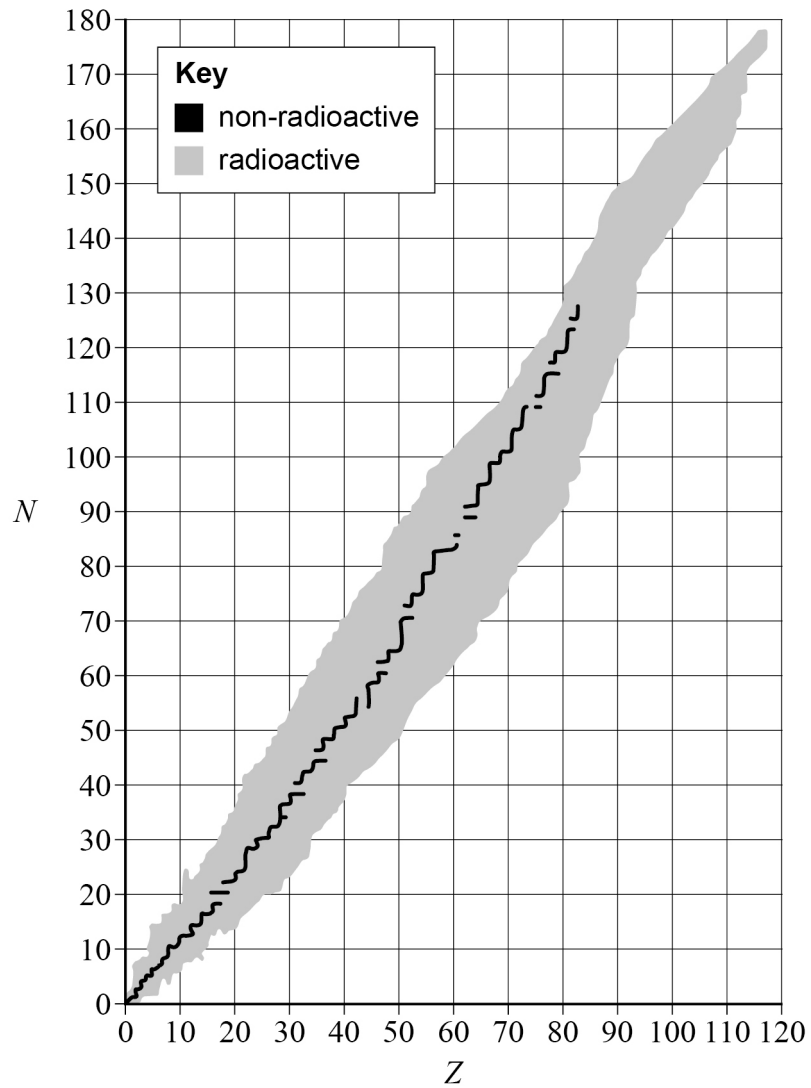

The nuclide  ${}_{45}^{115}\text{Rh}$  is likely to decay by

[1 mark]

- A  $\alpha$  emission.
- B  $\beta^+$  emission.
- C  $\beta^-$  emission.
- D electron capture.



**3 1**

Uranium-238 absorbs a neutron in the first stage in a series of nuclear reactions that end in a nucleus Z.

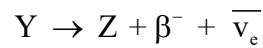
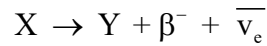
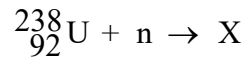

How many neutrons does Z have?

**[1 mark]**

- A** 144
- B** 145
- C** 149
- D** 237

**3 2**

A rock sample is found to contain the stable isotope lead-207. When it was formed, the rock contained uranium-235 but did not contain any lead-207.

Uranium-235 decays by a series of steps into lead-207. The half-life of uranium-235 is 0.71 billion years. The half-lives of the nuclides in the intermediate steps are negligible.

The sample of rock now contains one atom of lead-207 for every four atoms of uranium-235.

How long ago was the rock formed?

**[1 mark]**

- A** 0.23 billion years
- B** 0.31 billion years
- C** 1.4 billion years
- D** 2.0 billion years

**25****END OF QUESTIONS**

**There are no questions printed on this page**

*Do not write  
outside the  
box*

**DO NOT WRITE ON THIS PAGE  
ANSWER IN THE SPACES PROVIDED**









**There are no questions printed on this page**

*Do not write  
outside the  
box*

**DO NOT WRITE ON THIS PAGE  
ANSWER IN THE SPACES PROVIDED**

**Copyright information**

For confidentiality purposes, all acknowledgements of third-party copyright material are published in a separate booklet. This booklet is published after each live examination series and is available for free download from [www.aqa.org.uk](http://www.aqa.org.uk)

Permission to reproduce all copyright material has been applied for. In some cases, efforts to contact copyright-holders may have been unsuccessful and AQA will be happy to rectify any omissions of acknowledgements. If you have any queries please contact the Copyright Team.

Copyright © 2024 AQA and its licensors. All rights reserved.

