

Please check the examination details below before entering your candidate information

Candidate surname

Other names

Centre Number

Candidate Number

--	--	--	--	--

--	--	--	--	--

## Pearson Edexcel Level 3 GCE

**Monday 17 June 2024**

Morning (Time: 2 hours 30 minutes)

Paper  
reference

**9PH0/03**

# Physics

**Advanced**

**PAPER 3: General and Practical Principles in Physics**

### You must have:

Scientific calculator and ruler

Data, Formulae and Relationships Booklet (enclosed)

Total Marks

### Instructions

- Use **black** ink or ball-point pen.
- If pencil is used for diagrams/sketches/graphs it must be dark (HB or B).
- **Fill in the boxes** at the top of this page with your name, centre number and candidate number.
- Answer **all** questions.
- Answer the questions in the spaces provided  
– *there may be more space than you need.*

### Information

- The total mark for this paper is 120.
- The marks for **each** question are shown in brackets  
– *use this as a guide as to how much time to spend on each question.*
- In questions marked with an **asterisk** (\*), marks will be awarded for your ability to structure your answer logically, showing how the points that you make are related or follow on from each other where appropriate.

### Advice

- Read each question carefully before you start to answer it.
- Try to answer every question.
- Check your answers if you have time at the end.
- You are advised to show your working in calculations including units where appropriate.

Turn over ►

P74470A

©2024 Pearson Education Ltd.  
E:1/1/1/1/1/



  
Pearson

Answer ALL questions in the spaces provided.

1 A student stretched a length of nylon fishing line using the apparatus shown below.

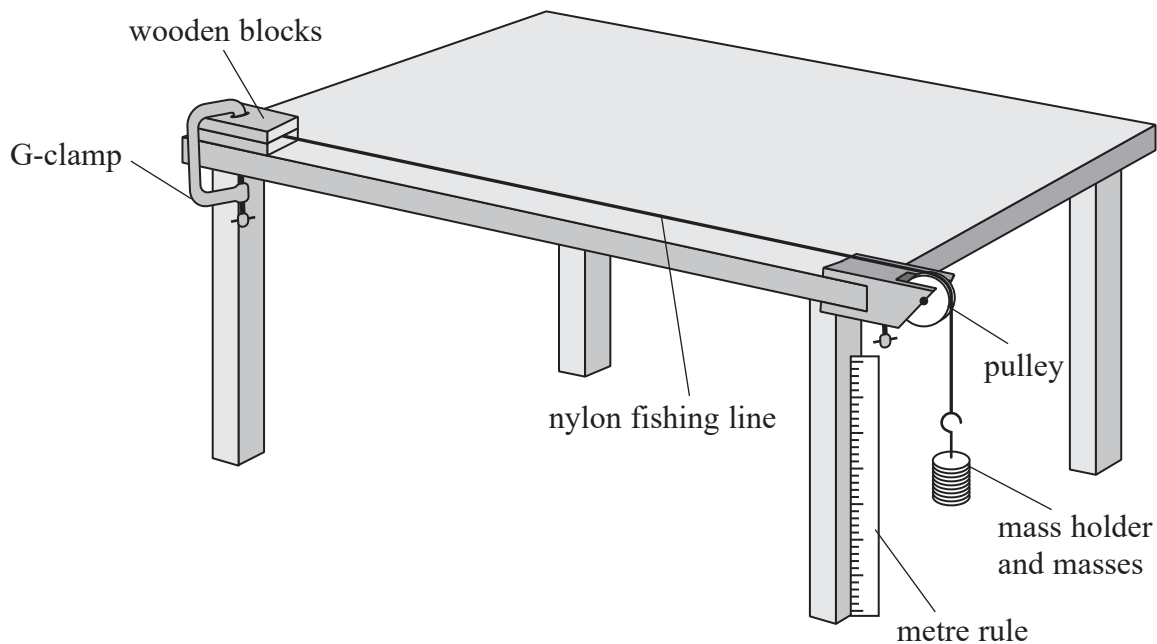

(a) The nylon fishing line was stretched by adding masses to the mass holder. The positions of the bottom of the mass holder were measured as masses were added. For each mass, the extension of the nylon fishing line was calculated. The student recorded the results, as shown in the table.

Mass / kg	Extension / cm
0.05	0.4
0.1	0.8
0.25	2.1
0.5	3.9
0.75	6.0
1.0	7.2

Criticise the recording of these results.

(2)

.....

.....

.....

.....

DO NOT WRITE IN THIS AREA

DO NOT WRITE IN THIS AREA

DO NOT WRITE IN THIS AREA



DO NOT WRITE IN THIS AREA

DO NOT WRITE IN THIS AREA

DO NOT WRITE IN THIS AREA

(b) Describe how the extension of the nylon fishing line could have been determined as accurately as possible.

(3)

.....

.....

.....

.....

.....

.....

.....

(c) The strain for the nylon fishing line at its yield point is 0.04

(i) State what is meant by yield point.

(1)

.....

.....

(ii) The original length of the nylon fishing line was 2.00 m.

Determine whether the fishing line was stretched beyond its yield point.

(2)

.....

.....

.....

.....

**(Total for Question 1 = 8 marks)**

---

.....

.....

.....

.....



P 7 4 4 7 0 A 0 3 3 2

- 2 A student made measurements to determine if some gold coins were made from pure gold. The coins that were available to the student are shown below.



(Source: © Bjoern Wylezich/Shutterstock)

- (a) The student used digital calipers to measure the thickness  $t$  and the diameter  $d$  of one of the coins.

- (i) Calculate the volume  $V$  of the coin, and the percentage uncertainty in  $V$ .

$$t = 1.54 \text{ mm}$$

$$d = 22.16 \text{ mm}$$

(7)

$$V = \dots\dots\dots$$

$$\text{Percentage uncertainty in } V = \dots\dots\dots$$



- (ii) The student measured the mass of the coin using an electronic balance.  
The balance had a resolution of 0.1 g.

Assess whether the coin could be made from pure gold.

density of pure gold =  $1.93 \times 10^4 \text{ kg m}^{-3}$

mass of coin = 11.2 g

(4)

.....

.....

.....

.....

.....

.....

.....

.....

.....

.....

.....

.....

.....

.....

.....

.....

.....

.....

.....

.....

.....

.....

- (b) The student's experimental method could have been improved.

Explain two changes the student could have made to the experimental method.

(4)

.....

.....

.....

.....

.....

.....

.....

.....

.....

.....

.....

.....

.....

.....

.....

.....

.....

.....

.....

.....

.....

.....

(Total for Question 2 = 15 marks)

DO NOT WRITE IN THIS AREA





DO NOT WRITE IN THIS AREA

DO NOT WRITE IN THIS AREA

DO NOT WRITE IN THIS AREA

**BLANK PAGE**



4 Helium is available in small metal canisters. The helium can be used to fill party balloons.

- (a) A full canister contains helium gas at a temperature of  $18.5^{\circ}\text{C}$  and a pressure of  $1.65 \times 10^7 \text{ Pa}$ . The canister is approximately spherical, with a radius of  $4.36 \times 10^{-2} \text{ m}$ .

Calculate the mass of helium gas in the full canister.

$$\text{mass of } 6.02 \times 10^{23} \text{ atoms of helium} = 4.00 \times 10^{-3} \text{ kg}$$

(5)

Mass of helium = .....





5 A student used springs to attach a trolley between two fixed supports, as shown.

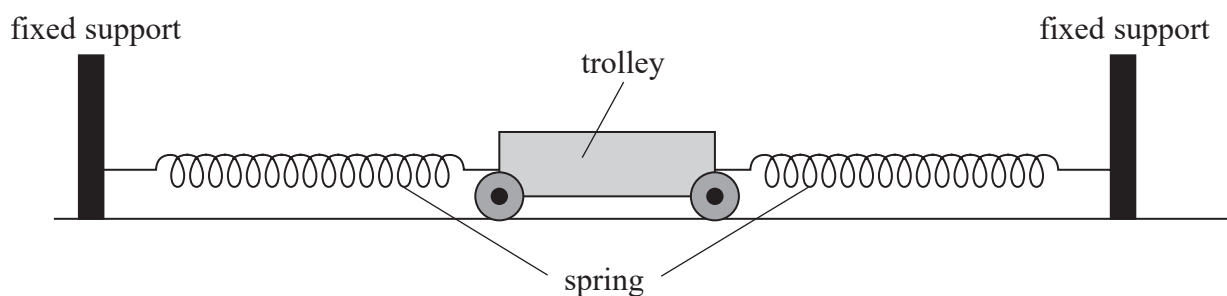

When displaced horizontally, the trolley oscillated with simple harmonic motion.

To determine the time period  $T$  of oscillation of the trolley, the student displaced the trolley from its equilibrium position and released it. As she released the trolley, she started a stopwatch. She stopped the stopwatch when the trolley had returned to its starting point.

(a) Explain how the procedure used by the student to determine  $T$  could have been improved.

(6)

.....

.....

.....

.....

.....

.....

.....

.....

.....

.....

.....

.....

.....

.....

.....

.....

.....

.....

.....

.....

.....

.....

.....

DO NOT WRITE IN THIS AREA

DO NOT WRITE IN THIS AREA

DO NOT WRITE IN THIS AREA





- 6 Rosslyn Chapel is a 15th century chapel in Scotland. Inside the chapel, small sandstone cubes protrude from a number of arches. It has been suggested that carvings on these cubes bear a resemblance to standing wave patterns that can be produced on a vibrating metal plate.

A metal plate is made to vibrate and sand is scattered evenly across its surface. At a certain frequency the sand moves to produce the standing wave pattern shown below.

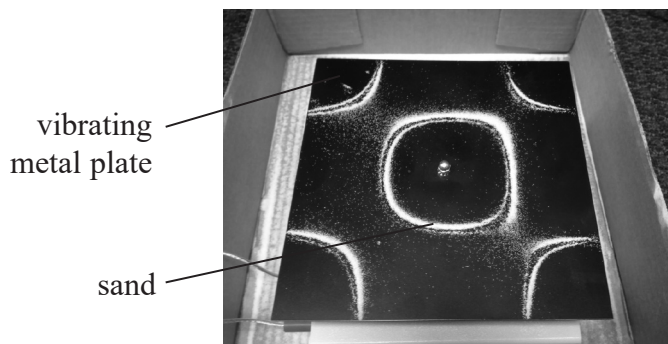

(Source: <https://skullsinthestars.com/2013/05/02/physics-demonstrations-chladni-patterns/#jp-carousel-7353>)

- (a) Explain why the sand moves to different positions when a standing wave is formed on the plate.

(3)

.....

.....

.....

.....

.....

.....



DO NOT WRITE IN THIS AREA

DO NOT WRITE IN THIS AREA

DO NOT WRITE IN THIS AREA

(b) The plate is set into movement by a vibration generator. The wavelength of the waves produced in the plate was estimated to be 0.32 m.

The signal applied to the vibration generator is shown on the oscilloscope trace below. The time base of the oscilloscope was set to  $0.50 \text{ ms div}^{-1}$ .

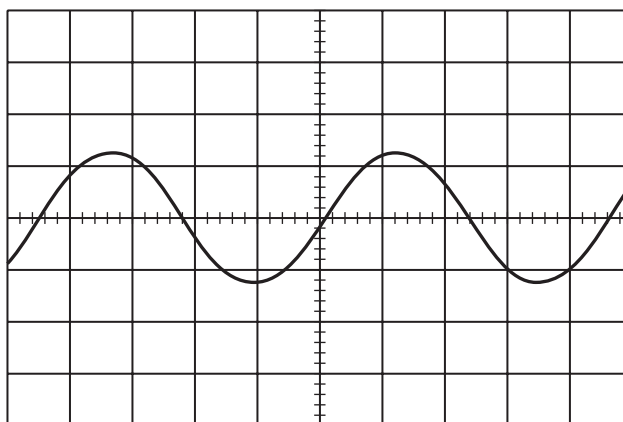

The waves produced in the plate travel at a speed much less than the speed of sound in air.

Evaluate whether the data supports a value for the speed of waves in the plate that is much less than the speed of sound in air.

speed of sound in air =  $340 \text{ m s}^{-1}$

(5)

.....

.....

.....

.....

.....

.....

.....

.....

.....

.....

.....



- (c) The speed of sound in air can be determined by creating a standing wave in a column of air. The diagram shows a tuning fork just above the open end of a tube.

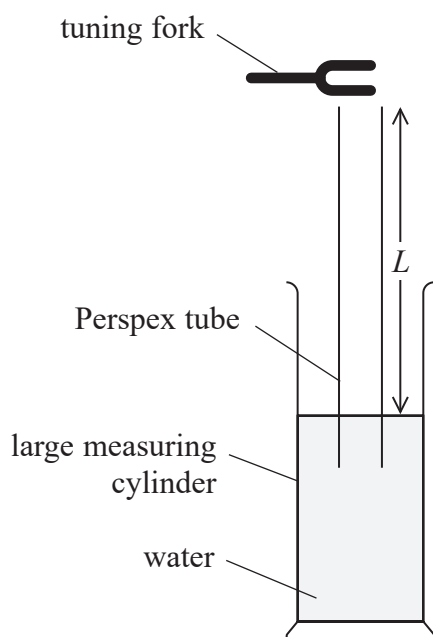

The tuning fork produces a sound wave of known frequency  $f$ . Several tuning forks are available, each with a different frequency.

A student adjusted the length  $L$  of the air column. A loud sound was heard when a standing wave was produced. A node was formed at the water surface, and an antinode was formed at the open end of the tube.

The student used values of  $L$  and  $f$  to determine a value for the speed of sound.

Describe a graphical method that the student could have used to determine a value for the speed of sound.

(3)

(Total for Question 6 = 11 marks)



DO NOT WRITE IN THIS AREA

DO NOT WRITE IN THIS AREA

DO NOT WRITE IN THIS AREA

**BLANK PAGE**



P 7 4 4 7 0 A 0 1 5 3 2

- 7 Radon is a radioactive gas. One isotope of radon,  ${}^{220}_{86}\text{Rn}$ , decays to polonium, Po, by emitting an alpha particle.

(a) Complete the nuclear equation for the decay of radon.

(2)



(b) Radon is produced in the ground and escapes into the atmosphere.

Explain why this is a safety hazard.

(2)

- (c) The diagram shows apparatus for monitoring the decay of radon in the laboratory. Radon gas is produced in the plastic bottle from the decay of radium. A small amount of radon is then inserted into the decay chamber by squeezing the plastic bottle. A current is produced between two electrodes inside the chamber. This current is amplified and recorded by the ammeter.

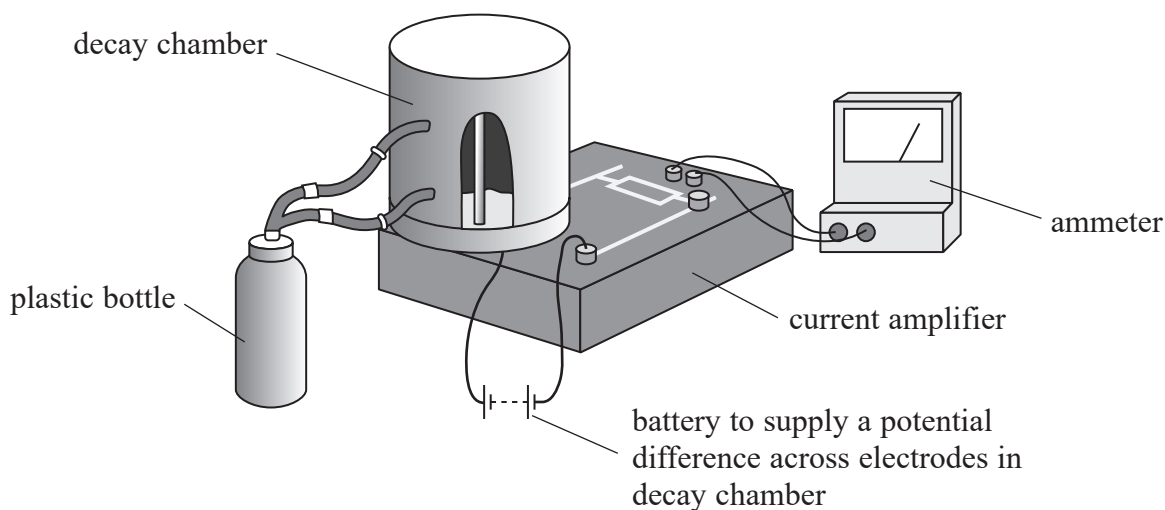

(i) Explain why a current is produced in the decay chamber.

(2)

.....

.....

.....

.....

(ii) A teacher is demonstrating the operation of the decay chamber to her class. She squeezes the bottle to introduce radon into the chamber.

She claims that within 450 s the activity of the radon in the chamber will be less than 1% of its initial value.

Assess whether her claim is correct.

half-life of radon = 55.6 s

(3)

.....

.....

.....

.....

.....

.....

.....

.....

**(Total for Question 7 = 9 marks)**

DO NOT WRITE IN THIS AREA

DO NOT WRITE IN THIS AREA

DO NOT WRITE IN THIS AREA





(b) When the modelling clay hits the pendulum bob, the pendulum swings to one side.

- (i) Show that the time taken for the pendulum bob to move from its lowest position to its highest position is about 0.6 s.

effective length of pendulum = 1.25 m

(3)

- (ii) The pendulum bob was then attached to a spring of stiffness  $0.12 \text{ N m}^{-1}$ . When the bob was displaced vertically and released, it oscillated with a time period equal to that of the pendulum.

Calculate the mass of the pendulum bob.

(2)

Mass of pendulum bob = .....

**(Total for Question 8 = 11 marks)**



- 9 A student carried out an experiment with a light dependent resistor (LDR). He connected the LDR in series with an ammeter and a power supply, as shown in the circuit diagram.

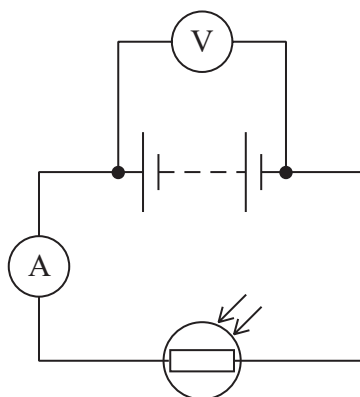

The student placed the LDR a known distance from a desk lamp, as shown.

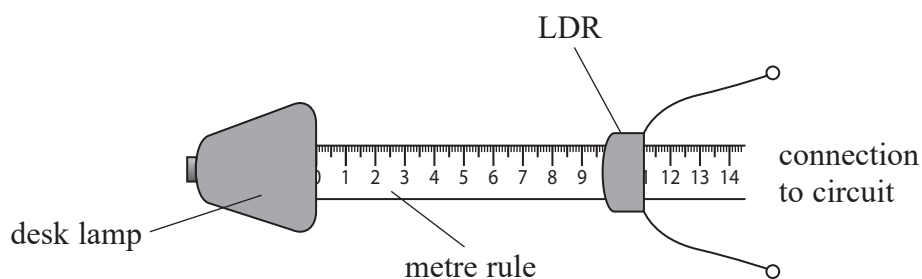

The student noted the reading on the ammeter as he brought the LDR closer to the lamp.

- (a) The student planned to vary the intensity of light incident upon the LDR by adjusting the distance  $x$  between the LDR and the lamp.

He thought that the intensity of light on the LDR would increase uniformly if he decreased  $x$  by equal intervals. He therefore planned to take ammeter readings as he decreased  $x$  from 20.0 cm to 10.0 cm in equal intervals.

- (i) Criticise the student's plan for data collection.

(3)



(ii) Explain one precaution that the student should take to ensure that results are accurate.

(2)

.....

.....

.....

.....

.....

.....

.....

.....

(b) Explain why the ammeter reading increased as the LDR was brought closer to the lamp. Your answer should include reference to the charge carriers in the LDR.

(3)

.....

.....

.....

.....

.....

.....

.....

.....

.....

**(Total for Question 9 = 8 marks)**

DO NOT WRITE IN THIS AREA

DO NOT WRITE IN THIS AREA

DO NOT WRITE IN THIS AREA



- 10 A 'jumperoo' is a harness, suspended by a vertical spring, into which a baby can be placed, as shown.



The jumperoo is adjusted so that the baby's feet are a few centimetres above the floor. If the baby is then displaced downwards and released, he oscillates vertically.

- (a) The graph shows how the acceleration  $a$  of the baby depends upon the displacement  $x$  of the baby from its equilibrium position.

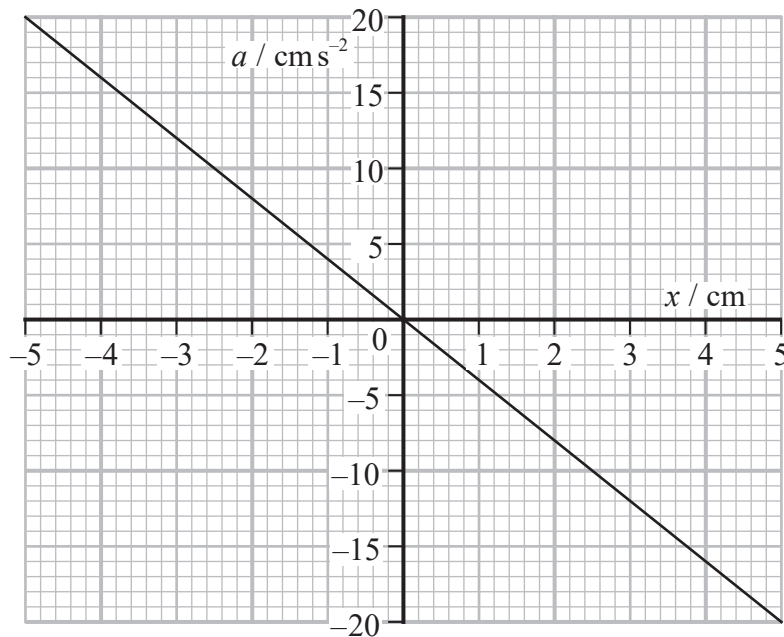

For safety reasons, it is suggested that the maximum velocity of the baby should not exceed  $0.5 \text{ ms}^{-1}$ .

Assess whether it is safe for the baby to oscillate in the jumperoo with an amplitude of 22 cm.

(3)

.....

.....

.....

.....

.....

.....

(b) The amplitude of the oscillations quickly decreases, so the baby has to push down on the floor to maintain the oscillations.

When the baby pushes at a particular frequency, the amplitude of oscillation increases to a maximum.

A baby of greater mass is placed in the jumperoo.

This baby pushes on the floor at a frequency that produces a maximum amplitude of oscillation.

Explain how this frequency compares with the frequency of pushing of the original baby.

A calculation is not necessary.

(3)

.....

.....

.....

.....

.....

.....

.....

.....

.....

.....

**(Total for Question 10 = 6 marks)**

DO NOT WRITE IN THIS AREA

DO NOT WRITE IN THIS AREA

DO NOT WRITE IN THIS AREA



P 7 4 4 7 0 A 0 2 3 3 2

11 A student connected a voltmeter to a potential divider, as shown in the circuit diagram.

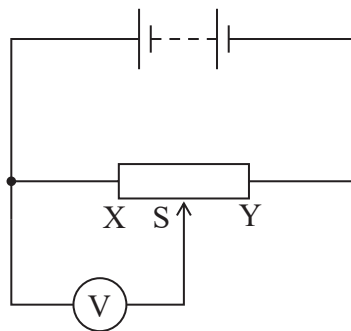

- (a) The potential divider was adjusted by moving sliding contact S from position X to position Y.

Explain how the voltmeter reading  $V$  depends upon the position of S.

(3)

.....

.....

.....

.....

.....

.....

.....



- (b) A filament bulb and ammeter were connected to the potential divider. The potential divider was used to vary  $V$  across the filament bulb. The ammeter gave the corresponding current  $I$  in the filament.

$I$  varied with  $V$ , as shown in the graph below.

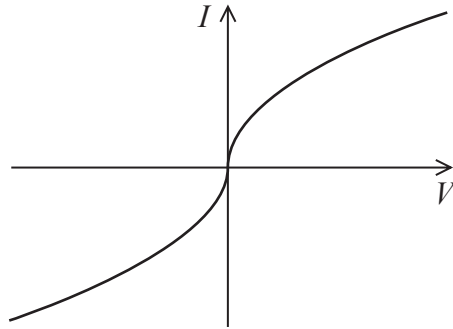

Explain the shape of the graph.

(2)

.....

.....

.....

.....

.....



- (c) The temperature  $T$  of the filament varies with the potential difference  $V$  across the filament according to the expression

$$T = aV^b$$

where  $a$  and  $b$  are constants.

- (i) Explain why a graph of  $\log T$  against  $\log V$  would give a straight line.

(2)

- (ii) Data for  $T$  and  $V$  is shown in the table below.

$T / \text{K}$	$V / \text{V}$		
1480	5.03		
1680	6.89		
1850	8.95		
2010	11.11		
2140	12.94		
2280	15.06		

Plot a graph of  $\log T$  against  $\log V$  on the grid opposite. Use the extra columns provided to show any processed data.

(5)

- (iii) Determine a value for  $b$  using your graph.

(2)

$b =$  .....



DO NOT WRITE IN THIS AREA

DO NOT WRITE IN THIS AREA

DO NOT WRITE IN THIS AREA

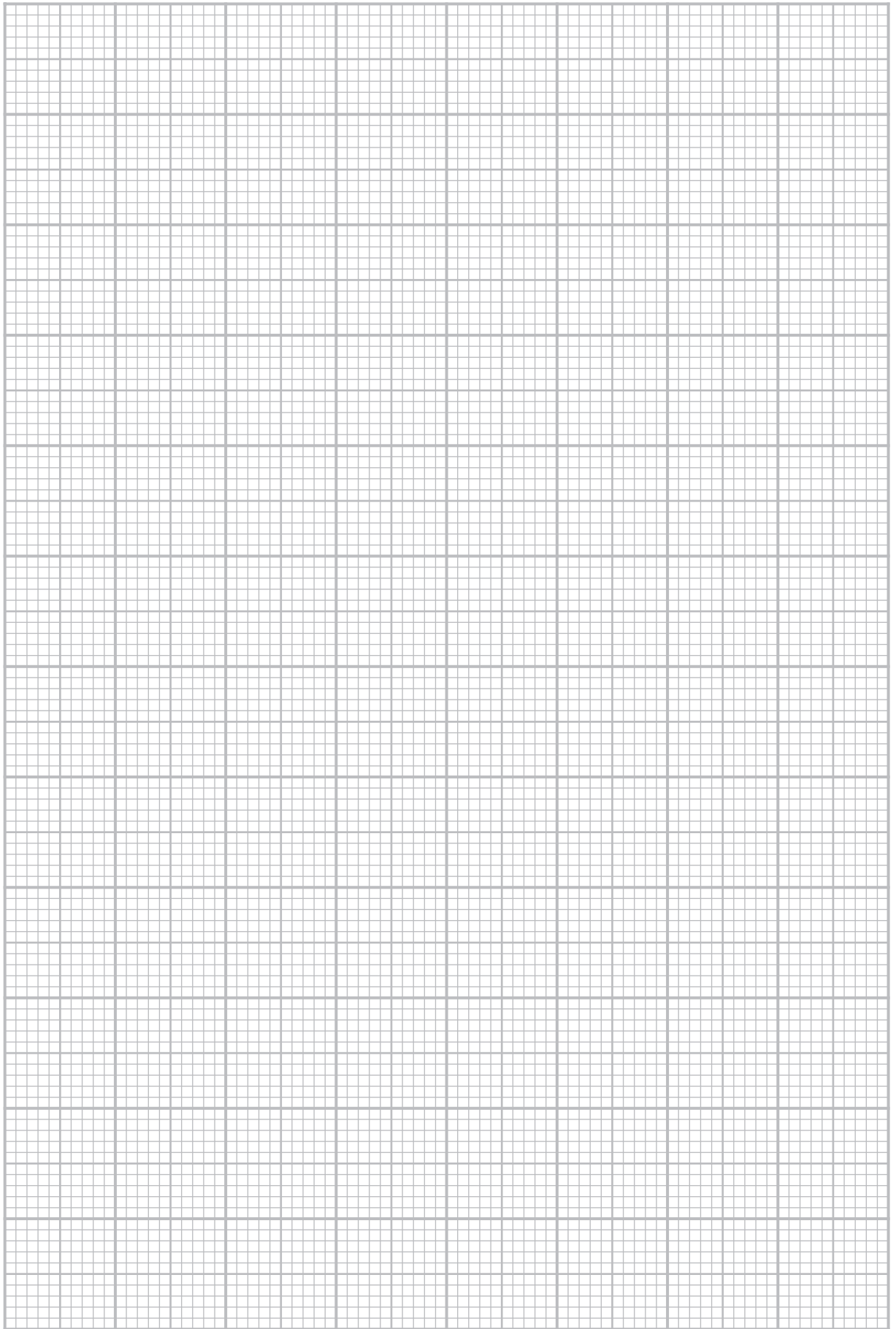

(Total for Question 11 = 14 marks)



12 Chocolate is a solid at room temperature, but melts just below body temperature.

- (a) A student investigated the viscosity of some melted chocolate using a falling-ball method. Since chocolate is opaque, a thin rod was attached to the ball so that the movement of the ball could be monitored. The apparatus is shown in the diagram.

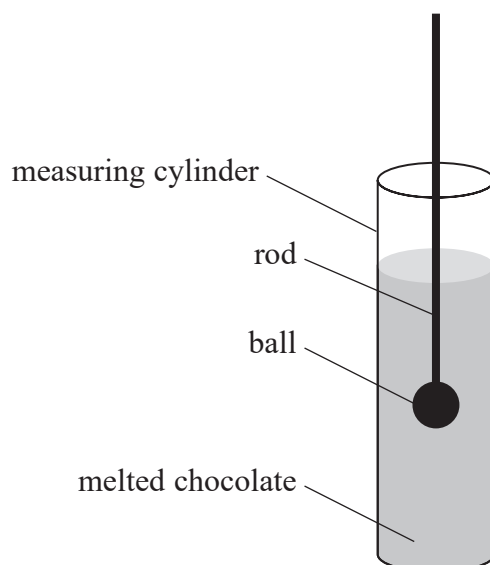

The chocolate was maintained at a constant temperature during the investigation.

- (i) The student used a stopwatch to measure the time  $t$  for the ball to fall 22.5 cm whilst travelling at its terminal velocity  $v$ .

Her results are shown in the table.

$t_1 / \text{s}$	$t_2 / \text{s}$	$t_3 / \text{s}$
9.6	9.9	9.6

$v$  is given by the formula

$$v = \frac{2r^2g(\rho_B - \rho_C)}{9\eta}$$

where

$r$  is the radius of the ball

$\rho_B$  is the density of the ball

$\rho_C$  is the density of the chocolate

$\eta$  is the viscosity of the chocolate.





(ii) Explain one reason why the student's data may have led to an inaccurate conclusion about the cocoa content.

(2)

.....

.....

.....

.....

DO NOT WRITE IN THIS AREA

DO NOT WRITE IN THIS AREA

DO NOT WRITE IN THIS AREA



(b) One type of chocolate melts at a temperature of  $32^{\circ}\text{C}$ .

The energy released when 65 g of this chocolate is digested is 345 kcal.

It is suggested that the energy used to melt a piece of this chocolate is at least 15% of the energy released when the chocolate is digested.

Assess the accuracy of this suggestion.

initial temperature of chocolate =  $15^{\circ}\text{C}$

specific heat capacity of chocolate =  $3.9 \times 10^3 \text{ J kg}^{-1} \text{ K}^{-1}$

specific latent heat of chocolate =  $1.50 \times 10^5 \text{ J kg}^{-1}$

1 kcal = 4200 J

(6)

---

(Total for Question 12 = 13 marks)

---

**TOTAL FOR PAPER = 120 MARKS**



DO NOT WRITE IN THIS AREA

DO NOT WRITE IN THIS AREA

DO NOT WRITE IN THIS AREA

**BLANK PAGE**



# Pearson Edexcel Level 3 GCE

**Monday 17 June 2024**

Morning (Time: 2 hours 30 minutes)

Paper  
reference

**9PH0/03**

## **Physics**

**Advanced**

**PAPER 3: General and Practical Principles in Physics**

**Data, Formulae and Relationships Booklet**

**Do not return this Booklet with the question paper.**

*Turn over* ►

**P74470A**

©2024 Pearson Education Ltd.  
E:1/1/1/1/1/



**Pearson**

### List of data, formulae and relationships

Acceleration of free fall	$g = 9.81 \text{ m s}^{-2}$	(close to Earth's surface)
Boltzmann constant	$k = 1.38 \times 10^{-23} \text{ J K}^{-1}$	
Coulomb law constant	$k = \frac{1}{4\pi\epsilon_0} = 8.99 \times 10^9 \text{ N m}^2 \text{ C}^{-2}$	
Electron charge	$e = -1.60 \times 10^{-19} \text{ C}$	
Electron mass	$m_e = 9.11 \times 10^{-31} \text{ kg}$	
Electronvolt	$1 \text{ eV} = 1.60 \times 10^{-19} \text{ J}$	
Gravitational constant	$G = 6.67 \times 10^{-11} \text{ N m}^2 \text{ kg}^{-2}$	
Gravitational field strength	$g = 9.81 \text{ N kg}^{-1}$	(close to Earth's surface)
Permittivity of free space	$\epsilon_0 = 8.85 \times 10^{-12} \text{ F m}^{-1}$	
Planck constant	$h = 6.63 \times 10^{-34} \text{ J s}$	
Proton mass	$m_p = 1.67 \times 10^{-27} \text{ kg}$	
Speed of light in a vacuum	$c = 3.00 \times 10^8 \text{ m s}^{-1}$	
Stefan-Boltzmann constant	$\sigma = 5.67 \times 10^{-8} \text{ W m}^{-2} \text{ K}^{-4}$	
Unified atomic mass unit	$u = 1.66 \times 10^{-27} \text{ kg}$	

#### Mechanics

Kinematic equations of motion

$$s = \frac{(u + v)t}{2}$$

$$v = u + at$$

$$s = ut + \frac{1}{2}at^2$$

$$v^2 = u^2 + 2as$$

Forces

$$\Sigma F = ma$$

$$g = \frac{F}{m}$$

$$W = mg$$

$$\text{moment of force} = Fx$$

Momentum

$$p = mv$$

#### Work, energy and power

$$\Delta W = F\Delta s$$

$$E_k = \frac{1}{2}mv^2$$

$$\Delta E_{\text{grav}} = mg\Delta h$$

$$P = \frac{E}{t}$$

$$P = \frac{W}{t}$$

$$\text{efficiency} = \frac{\text{useful energy output}}{\text{total energy input}}$$

$$\text{efficiency} = \frac{\text{useful power output}}{\text{total power input}}$$



## Electric circuits

Potential difference

$$V = \frac{W}{Q}$$

Resistance

$$R = \frac{V}{I}$$

Electrical power and energy

$$P = VI$$

$$P = I^2R$$

$$P = \frac{V^2}{R}$$

$$W = VIt$$

Resistivity

$$R = \frac{\rho l}{A}$$

Current

$$I = \frac{\Delta Q}{\Delta t}$$

$$I = nqvA$$

## Materials

Density

$$\rho = \frac{m}{V}$$

Stokes' law

$$F = 6\pi\eta r v$$

Hooke's law

$$\Delta F = k\Delta x$$

Young modulus

$$\text{Stress } \sigma = \frac{F}{A}$$

$$\text{Strain } \varepsilon = \frac{\Delta x}{x}$$

$$E = \frac{\sigma}{\varepsilon}$$

Elastic strain energy

$$\Delta E_{\text{el}} = \frac{1}{2}F\Delta x$$

## Waves and particle nature of light

Wave speed

$$v = f\lambda$$

Speed of a transverse wave on a string

$$v = \sqrt{\frac{T}{\mu}}$$

Intensity of radiation

$$I = \frac{P}{A}$$

Power of a lens

$$P = \frac{1}{f}$$

$$P = P_1 + P_2 + P_3 + \dots$$

Thin lens equation

$$\frac{1}{u} + \frac{1}{v} = \frac{1}{f}$$

Magnification for a lens

$$m = \frac{\text{image height}}{\text{object height}} = \frac{v}{u}$$

Diffraction grating

$$n\lambda = d \sin \theta$$

Refractive index

$$n_1 \sin \theta_1 = n_2 \sin \theta_2$$

$$n = \frac{c}{v}$$

Critical angle

$$\sin C = \frac{1}{n}$$

Photon model

$$E = hf$$

Einstein's photoelectric equation

$$hf = \phi + \frac{1}{2}mv_{\text{max}}^2$$

de Broglie wavelength

$$\lambda = \frac{h}{p}$$



## Further mechanics

Impulse

$$F\Delta t = \Delta p$$

Kinetic energy of a non-relativistic particle

$$E_k = \frac{p^2}{2m}$$

Motion in a circle

$$v = \omega r$$

$$T = \frac{2\pi}{\omega}$$

$$F = ma = \frac{mv^2}{r}$$

$$a = \frac{v^2}{r}$$

$$a = r\omega^2$$

$$F = mr\omega^2$$

## Fields

Coulomb's law

$$F = \frac{Q_1 Q_2}{4\pi\epsilon_0 r^2}$$

Electric field strength

$$E = \frac{F}{Q}$$

$$E = \frac{Q}{4\pi\epsilon_0 r^2}$$

$$E = \frac{V}{d}$$

Electric potential

$$V = \frac{Q}{4\pi\epsilon_0 r}$$

Capacitance

$$C = \frac{Q}{V}$$

Energy stored in a capacitor

$$W = \frac{1}{2} QV$$

$$W = \frac{1}{2} CV^2$$

$$W = \frac{1}{2} \frac{Q^2}{C}$$

Capacitor discharge

$$Q = Q_0 e^{-t/RC}$$

$$I = I_0 e^{-t/RC}$$

$$V = V_0 e^{-t/RC}$$

$$\ln Q = \ln Q_0 - \frac{t}{RC}$$

$$\ln I = \ln I_0 - \frac{t}{RC}$$

$$\ln V = \ln V_0 - \frac{t}{RC}$$

In a magnetic field

$$F = BIl \sin \theta$$

$$F = Bqv \sin \theta$$

Faraday's and Lenz's laws

$$\mathcal{E} = \frac{-d(N\phi)}{dt}$$

Root-mean-square values

$$V_{\text{rms}} = \frac{V_0}{\sqrt{2}}$$

$$I_{\text{rms}} = \frac{I_0}{\sqrt{2}}$$



## Nuclear and particle physics

In a magnetic field

$$r = \frac{p}{BQ}$$

## Thermodynamics

Heating

$$\Delta E = mc\Delta\theta$$

$$\Delta E = L\Delta m$$

Molecular kinetic theory

$$\frac{1}{2}m\langle c^2 \rangle = \frac{3}{2}kT$$

$$pV = \frac{1}{3}Nm\langle c^2 \rangle$$

Ideal gas equation

$$pV = NkT$$

Stefan-Boltzmann law

$$L = \sigma AT^4$$

$$L = 4\pi r^2\sigma T^4$$

Wien's law

$$\lambda_{\max} T = 2.898 \times 10^{-3} \text{ m K}$$

## Space

Intensity

$$I = \frac{L}{4\pi d^2}$$

Redshift of electromagnetic radiation

$$z = \frac{\Delta\lambda}{\lambda} \approx \frac{\Delta f}{f} \approx \frac{v}{c}$$

Cosmological expansion

$$v = H_0 d$$

## Nuclear radiation

Mass-energy

$$\Delta E = c^2\Delta m$$

Radioactive decay

$$A = \lambda N$$

$$\frac{dN}{dt} = -\lambda N$$

$$\lambda = \frac{\ln 2}{t_{1/2}}$$

$$N = N_0 e^{-\lambda t}$$

$$A = A_0 e^{-\lambda t}$$

## Gravitational fields

Gravitational force

$$F = \frac{Gm_1 m_2}{r^2}$$

Gravitational field strength

$$g = \frac{Gm}{r^2}$$

Gravitational potential

$$V_{\text{grav}} = \frac{-Gm}{r}$$

## Oscillations

Simple harmonic motion

$$F = -kx$$

$$a = -\omega^2 x$$

$$x = A \cos \omega t$$

$$v = -A\omega \sin \omega t$$

$$a = -A\omega^2 \cos \omega t$$

$$T = \frac{1}{f} = \frac{2\pi}{\omega}$$

$$\omega = 2\pi f$$

Simple harmonic oscillator

$$T = 2\pi \sqrt{\frac{m}{k}}$$

$$T = 2\pi \sqrt{\frac{l}{g}}$$

END OF DATA, FORMULAE AND RELATIONSHIPS LIST



**BLANK PAGE**



**BLANK PAGE**



**BLANK PAGE**

